

TOWING 2024

Trailer & Vehicle Accessories



JIULONG INDUSTRIAL CO.LTD
NINGBO JIULONG HARDWARE CO.,LTD

Factory Add: NO.33 Technology Street, Ninghai,Ningbo
Office Add: 5F, Guangbo International Centre,No.1357
Yinxian Road,Ningbo,China

电话 (Tel) : 0086-574-82815295
手机 (Mob) : 0086-13989392999 (Wechat,WhatsApp)
传真 (Fax) : 0086-574-82815296
邮编 (P.C) : 315100
网址 (Web) : www.nb-jiulong.com / www.jltiedown.com
邮箱 (Email) : sales@jlhardware.com / jack@jlhardware.com



JIULONG INDUSTRIAL CO.LTD
NINGBO JIULONG HARDWARE CO.,LTD

九隆五金 Jiulong Hardware

COMPANY PROFILE



NINGBO JIU LONG HARDWARE CO.,LTD. is a group company which owns two other subsidiaries: Zhejiang Jin Long Machinery Rigging CO.,LTD. and Ninghai Shuanggen Rubber &Plastic Co.,Ltd. It is located in Ninghai High-tech Industrial park Ningbo city--well- know as eastern pearl of China with beautiful sight-seeing. As the park is just near to the express way and main road, the transportation here is very convenient with Ning Bo international airport, Beiluo port just nearby.

Our services cover designing, manufacturing and sales of cargo control product, lifting and lashing hardware , truck parts, trailer products, supermarket shelves and shopping carts, machinery and riggings. There are over 400 0 products , among them 25 have got national patent. Owing to our refined design, original appearance and excellent workmanship, our products are now popular in over ten countries and areas like the United States, Germany, UK, France, the Netherland, Poland, Mexico and Taiwan etc.

For years, we have been the manufacturing company in our areas and have won the titles as city is "Contract stressed and credit reliable" company, AAA credit ranking company, we also got Achievement Award from intertek for WCA(Workplace Conditions Assessment)

Our fixed asset is over RMB 250million (USD40million) and the company covers over 100,000 square meters with buildings of 80000 square meters. Totally we have 1100 employees, 120 of them are junior and senior engineers, 150 are skilled technicians, we total have 3 big plant base on different product range.

Here following are the main equipment we have:

Imported auto chrome-painting line	2 EA
Imported auto powder-painting line	4 EA
Imported auto zinc-painting line	6 EA
Imported threading-drawing machine	4 EA
Imported alignment machine	20 EA
Imported spot-welding machine	40 EA
Imported robot welding machine	6 EA
Imported bending machine	4 EA
Mould finish-machining equipment	30 EA
100T-500T Hydraulic press Machine	10 EA
Large scale Hydraulic plate-cutting machine	2 EA
5T-250T Punch machine	60 EA
160T-1000T friction press	30 EA
Forging machine(from 400T to 1200T)	12 EA
Imported Webbing sewing machine	20 EA
webbing stitching machine	30 EA
Testing machine	6 EA

We are rapidly growing into a high-tech manufacturing company specialized in the production of argo control product, lifting and lashing hardware , truck parts, trailer products, supermarket shelves and shopping carts, machinery and riggings. series products with our advanced equipment, high efficiency stuffs, aggressive R & D and strong exploring spirit.

We can not only design and make all kinds of products within our product lines, we have set up an overall quality-control system from the raw material to finished products also. This enables us to pass ISO9001 and ISO 14000 approval.

We always hold our company idea "result-oriented, innovation, hard-working and surpassing" and this beings our unique company culture as "frank behaving, steady working, aggressive exploring and life-long studying" and our operation principle as "Innovation, sincere service, credit-stressing and supreme-quality".

We'd like to provide our customers with products of big variety, high quality and attractive appearance.



INDEX

Page1.....STANDARD TITCH BALLS
Page2-3.....BALL MOUNT
Page4.....TARAILER COUPLER
Page5-6.....TRALLER LOCK
Page7-8.....TRAILER JACK
Page9.....HAND WINCH
Page10.....PINTLE HOOK
Page11-12.....BIKE RACK
Page13.....CARGO CARRIER
Page14.....STOP/TURN/TAILLIGHTS
Page15.....BIKE RACK
Page16-18.....WIRNING KIT
Page19.....TOW PORES AND STRAPS
Page 20-22.....LANDING GEAR

STANDARD HITCH BALLS

www.nb-jiulong.com
www.Jiulongusa.com



Part No.	Ball Diameter	Shank Diameter	Shank Length	Finish	Capacity (lbs)
JL9807-1	1-7/8"	3/4"	2-3/8"	Chrome	2000
JL9807-2	1-7/8"	3/4"	1-1/2"	Chrome	2000
JL9807-3	1-7/8"	1"	2"	Chrome	2000
JL9807-4	2"	3/4"	2-3/8"	Chrome	3500
JL9807-5	2"	1"	2"	Chrome	6000
JL9807-6	2"	3/4"	1-1/2"	Chrome	3500
JL9807-7	2-5/16"	1"	2"	Chrome	6000
JL9807-8	2-5/16"	1-1/4"	2-1/2"	Chrome	6000



50MM THREADED TOWBALLS

Part No.	Ball Diameter	Shank Diameter	Shank Length	Finish	Capacity (lbs)
JL9808-1	50mm	7/8"	2"	Chrome	5000
JL9808-2	50mm	7/8"	2-1/8"	Chrome	5000
JL9808-3	50mm	7/8"	2-1/2"	Chrome	5000



50MM THREADED TOWBALLS

Part No.	Ball Diameter	Shank Diameter
JL9812Z	Zinc	Fits for a two-bolt flange towbar, zinc finish
JL9812B	Black	Fits for a two-bolt flange towbar, black finish



STANDARD HITCH BALLS

BALL MOUNT

www.nb-jiulong.com
www.Jiulongusa.com



BALL MOUNT

www.nb-jiulong.com
www.Jiulongusa.com



Ball Mount

Part No.	Specifications	Ball Hole Diameter	Length	Drop	Rise
JL9809-1	2"	1"	8-1/8"	2-1/8"	7/8"
JL9809-2	2"	1"	8-1/4"	2"	3-4"
JL9809-3	3"	1"	7-7/8"	3-1/4"	2"
JL9809-4	4"	1"	8-1/4"	4-1/4"	3"
JL9809-5	5"	1"	9"	4-15/16"	3-11/16"
JL9809-6	6"	1"	9-1/2"	5-15/16"	4-11/16"



Part No.	Receiver Tube size	Specifications	Finish	Capacity (lbs)
JL9810-1	2**2"	1-7/8"Ball,with 5/8" pin	black	6000
JL9810-2	2**2"	2"Ball,with 5/8" pin	black	6000



Part No.	Item Name	Tube size	Length	Capacity (lbs)
JL9811-1	1-1/4"	2"	6"	3500
JL9811-2	1-1/4"	2"	10"	3500



DUAL BALL MOUNTS - DROP CUT

Part No.	Receiver Tube size	Drop	Ball Size	Ball Finish	Shank Finish	Length	Capacity (lbs)	Shank
JL9813-1	2**2	2"	1-7/8"	Black	Black	8-1/4"	2000	Hollow
			2"			8-1/4"	6000	
JL9813-2	2**2	2"	2"	Chrome	Black	8-1/4"	6000	Hollow
			2-5/16"			8-1/4"	6000	
JL9813-3	2**2	2"	1-7/8"	Chrome	Black	8-1/4"	2000	Solid
			2"			8-1/4"	6000	
JL9813-4	2**2	2"	2"	Black	Black	8-1/4"	6000	Solid
			2-5/16"			8-1/4"	6000	



Part No.	Receiver Tube size	Specifications	Ball Finish	Shank Finish	Capacity (lbs)
		1-7/8" Ball			3500
JL9814	2**2"	2" Ball	Black or Chrome	Black	600
		2-5/16" Ball			10000



Part No.	Description	Opening	Ball Size	Length	Drop	Rise	Capacity (lbs)
			1-7/8"				6000
JL9815	Adjustable	2**2"	2"	16"	6"	6"	7500
			2-5/16"				10000



BALL MOUNT

BALL MOUNT

TARAILER COUPLER

www.nb-jiulong.com
www.Jiulongusa.com



Part No.	Specifications	Finish	Capacity (lbs)
JL9801	1-7/8"*2-1/2"	Zinc Plated	2000
JL9802	1-7/8"*2"	Zinc Plated	2000
JL9803	1-7/8"*3"	Zinc Plated	2000
JL9804	2"*2-1/2"	Zinc Plated	3500
JL9805	2"*2"	Zinc Plated	3500
JL9806	2"*3"	Zinc Plated	3500



TARAILER COUPLER

Part No.	Specifications	Finish	Capacity (lbs)
JL9816	50*50mm Square tube	Zinc Plated	3500
JL9817	50*60mm Square tube	Zinc Plated	3500
JL9818	50*35mm Circular tube	Zinc Plated	3500



Part No.	Specifications	Finish	Capacity (lbs)
JL9819	2"	Black	5000
JL9820	2-5/16"	Black	10000



TRALLER LOCK

www.nb-jiulong.com
www.Jiulongusa.com



UNIVERSAL COUPLER LOCK

Part No. [Redacted]

JL9821 UNIVERSAL COUPLER LOCK
Ratchet dwsign with six locking positions Fits 1-7/8",2"and 2-5/16" couplers



DUAL, BENT PIN RECEIVER LOCK

Part No. [Redacted]

JL9822 LOCK DUAL PIN 3/PDQ RTP LOCK
with two shank, 1/2"&5/8"



DRAW BAR LOCK

Part No. [Redacted]

JL9823-1 LOCK 1/2" HITCH PIN PKG LOCK



DRAW BAR LOCK

Part No. [Redacted]

JL9823-2 LOCK 5/8" HITCH PIN-CLASS III LOCK



TRALLER LOCK

TRALLER LOCK

www.nb-jiulong.com
www.Jiulongusa.com



COUPLER LOCKING DEVICES

Part No.

JL9824 COUPLER LOCK-PACKAGED LOCK



BARREL STYLE RECEIVER LOCK

Part No.

JL9825 LOCK 5/8 DOGBONE W/PUSHBUTTON LOCK



BARREL STYLE BENT PIN LOCK

Part No.

JL9826 LOCK 5/8 BENT PIN LOCK



TRAILER JACK



JL9831



JL9832

Model	Capacity	Packing	QTY/CTN	N.W (KG)	G.W (KG)	MEAS(MM)
JL9831	200LBS/910KG	Carton	20	10	12	500*200*175
JL9832	1200LBS/545KG	Carton	5	6	7	495*185*265

TRAILER JACK

www.nb-jiulong.com
www.Jiulongusa.com



JL9827A



JL9827B



JL9827C

Model	Capacity	Travel	Handle Type	Mounting Style	Packing	QTY/CTN	N.W (KG)	G.W (KG)	MEAS(MM)
JL9827A	1000LB/454KG	10"	Side	Blot-on Mount	Carton	1	6	6.5	550*175*255
JL9827B	1500LB/682KG	10"	Side	Blot-on Mount	Carton	1	8.8	9.5	550*175*255
JL9827C	2000LBS/908KG	10"	Side	Weld-on Mount	Carton	1	6	6.5	445*210*255



JL9828A



JL9828B



JL9828C



JL9828D

Model	Capacity	Travel	Handle Type	Mounting Style	Packing	QTY/CTN	N.W (KG)	G.W (KG)	MEAS(MM)
JL9828A	2000LBS/908KG	14"	Top	A-Frame	Carton	1	4.5	5	560*145*210
JL9828B	2000LBS/908KG	10"	Side	Weld-on Tube Incl	Carton	1	5.5	6	470*210*270
JL9828C	2000LBS/908KG	14"	Top	Weld-on Tube Incl	Carton	1	6	6.5	565*210*130
JL9828D	2000LBS/908KG	14"	Side	A-Frame	Carton	1	4.8	5.2	585*250*135

TRALLER LOCK

TRALLER LOCK

TRAILER JACK

www.nb-jiulong.com
www.Jiulongusa.com



JL9829A



JL9829B



JL9829C

Model	Capacity	Travel	Handle Type	Mounting Style	Packing	QTY/CTN	N.W (KG)	G.W (KG)	MEAS(MM)
JL9829A	3500LBS/1591KG	15"	Side	Weld-on Tube Incl	Carton	2	16	18	650*300*240
JL9829B	3500LBS/1591KG	15"	Side	Weld-on Tube Incl	Carton	2	14	16	650*300*245
JL9829C	3500LBS/1591KG	15"	Side	A-Frame	Carton	2	11	12	595*215*125



JL9830A



JL9830B



JL9830C

Model	Capacity	Travel	Handle Type	Mounting Style	Packing	QTY/CTN	N.W (KG)	G.W (KG)	MEAS(MM)
JL9830A	5000LBS/2272KG	15"	Top	A-Frame	Carton	12	5	5.4	560*145*210
JL9830B	5000LBS/2272KG	15"	Side	Weld-on Tube Incl	Carton	2	20	24	650*300*240
JL9830C	5000LBS/2272KG	15"	Side	Weld-on Tube Incl	Carton	2	16	18	650*300*240

HAND WINCH

www.nb-jiulong.com
www.Jiulongusa.com



ITEM	W.L.L LBS	Gear Ratio	Rated Pull	Qty/CTN (PCS)	G/W (kgs)	N.W (kgs)	Meas (cm)
JL9701-1	800	3.1:1	363	6	11	1	41*38*15
JL9701-2	1200	4.1:1	545	6	15	14	44*40*16
JL9701-3	1400	4.1:1	635	6	15.5	14.5	44*40*16
JL9701-4	2000	4.1:1	908	4	18	17	38*34*26
JL9701-5	2500	4:01	1135	4	21	20	40*32*26



ITEM	W.L.L LBS	Cable	Gear Ratio	Rated Pull	Qty/CTN (PCS)	G/W (kgs)	N.W (kgs)	Meas (cm)
JL9703-1	600	Φ 4.2mm*7m	3.1:1	272	6	15	14	41*38*15
JL9703-2	800	Φ 4.2mm*8m	3.1:1	363	6	15.5	14.5	41*38*15
JL9703-3	1000	Φ 4.5mm*8m	4.1:1	454	6	19	18	44*40*16
JL9703-4	1200	Φ 4.5mm*10m	4.1:1	545	6	21	20	44*40*16
JL9703-5	1400	Φ 4.5mm*10m	4.1:1	635	6	20.5	19.5	44*40*16
JL9703-6	1600	Φ 5mm*10m	4.1:1	726	6	21	20	44*40*16
JL9703-7	1800	Φ 5mm*8m	4.1:1	820	4	22	21	38*34*26
JL9703-8	200	Φ 5mm*10m	4.1:1	908	4	23	22	38*34*26
JL9703-9	2500	Φ 5mm*8m	4:01	1135	4	24	23	40*32*26



ITEM	W.L.L LBS	Strap	Gear Ratio	Rated Pull	Qty/CTN (PCS)	G/W (kgs)	N.W (kgs)	Meas (cm)
JL9702-1	600	50mm*7m	3.1:1	272	6	13.5	12.5	41*38*15
JL9702-2	1000	50mm*10m	4.1:1	454	6	17.5	16.5	44*40*16
JL9702-3	1500	50mm*10m	4.1:1	681	6	19	18	44*40*16
JL9702-4	1800	50mm*10m	4.1:1	820	4	20.5	19.5	38*34*26
JL9702-5	2500	50mm*10m	4:01	1135	4	22	21	40*32*26



TRAILER LOCK

TRAILER LOCK

PINTLE HOOK

www.nb-jiulong.com
www.Jiulongusa.com



BIKE RACK

www.nb-jiulong.com
www.Jiulongusa.com



JL9833, JL9834, JL9835

1-7/8" BALL AND PINTLE, Ball Finish: Black
2" BALL AND PINTLE, Ball Finish: Black
2-5/16" BALL AND PINTLE, Ball Finish: Black



JL9836

regular pintle (5ton) Black



JL9837, JL9838

regular pintle (10ton) Black
regular pintle (15ton) Black



JL9839-1, JL9839-2, JL9839-3, JL9839-4

With 1 7/8" ball and pintle
With 2" ball and pintle
With 2 5/16" ball and pintle
With 50mm ball and pintle



JL9840

5-ton receiver mount pintle hook

Art. No	Description
JL9850-1	1.Hitch Bike Carrier in steel 2 bikes with lock can fold down 2. hitch for 1-1/4 or 2 inch changeable
JL9850-2	1.Hitch Bike Carrier in steel 2. 3 bikes with lock can fold down 3. fix on the 1-1/4 and 2 inch receiver
JL9850-3	1.Hitch Bike Carrier in steel 2. 4 bikes with lock can fold down 3. fix on the 1-1/4 and 2 inch receiver



Art. No	Max laoding kg	Inner box cm	Master Carton(CM)	Quantity per max ctn.	G.N weight (kg)
JL9850-1	30	/	69*34*16	1	7/6.5
JL9850-2	45	/	69*34*16	1	8/7.0
JL9850-3	60	/	69*34*16	1	9.5/8

Art. No	Description
JL9850-4	1.Hitch Bike Carrier in Aluminum 2.3 bikes with lock can carry on 3.Control the speed: 100km/h 4.Common use



Art. No	Max laoding kg	Inner box cm	Master Carton(CM)	Quantity per max ctn.	G.N weight (kg)
JL9850-4	80	/	113*64*34.5	1	10/14.2

TRALLER LOCK

TRALLER LOCK

BIKE RACK

www.nb-jiulong.com
www.Jiulongusa.com



Art. No	Description
JL9850-5	1.Hitch Bike Carrier in steel 2.AT most 2 bikes with lock can carry 3.Black or grey



Art. No	Max loading kg	Inner box cm	Master Carton(CM)	Quantity per max ctn.	G.N weight (kg)
JL9850-5	30	/	58*44*53.5	4	19.5/20.5

Art. No	Description
JL9850-6	1.Hitch Bike Carrier in steel 2.AT most 3 bikes with lock can carry 3.Black or grey



Art. No	Max loading kg	Inner box cm	Master Carton(CM)	Quantity per max ctn.	G.N weight (kg)
JL9850-6	45	1	76*55*55	4	20/21

Art. No	Description
JL9850-7	1..Hitch Bike Carrier in steel 2.AT most 2 bikes with lock can carry 3.Black or grey



Art. No	Max loading kg	Inner box cm	Master Carton(CM)	Quantity per max ctn.	G.N weight (kg)
JL9850-7	45	1	80*54*52	4	15/16

CARGO CARRIER

www.nb-jiulong.com
www.Jiulongusa.com



JL9851

- 1:basket dimension measure 60"x20"x6";
- 2:made t ofit 2" receiver hitch;
- 3:heavy duty steel 5/8" diamater tubular conctruction;
- 4:expanded steel mesh floor;
- 5:easy to install 2-piece bolt together unit;
- 6:sides are 6" high to keep cargo secure and in place



JL9852

- 1:basket dimension measure 60"x20"x6";
- 2:made t ofit 2" receiver hitch;
- 3:heavy duty steel 5/8" diamater tubular conctruction;
- 4:expanded steel mesh floor;
- 5:easy to install 2-piece bolt together unit;
- 6:sides are 6" high to keep cargo secure and in place



JL9853

- N.W: 14.8kgs
- G.W: 15.8kgs
- Package Size: 130x52.5x22cm
- Overall Size : 127x74x20cm



TRAILER LOCK

TRAILER LOCK

STOP/TURN/TAILLIGHTS

www.nb-jiulong.com
www.Jiulongusa.com



BIKE RACK

www.nb-jiulong.com
www.Jiulongusa.com



LED LOW PROFILE TAILLIGHT & TAIL LAMP KIT

- LED Light rated at 100,000 hours - no bulbs to change
- Taillight's are waterproof and are suitable for the Marine Environment
- Meets/exceeds all DOT requirements for trailers over 80" wide
- Kit contains two taillights, one license plate bracket, one 25' wishbone trailer harness, one 48" connector, mounting hardware and installation instructions



JL9854-1 LED low profile trailer light kit

JL9854-2 LED low profile trailer, right / curbside

JL9854-3 LED low profile trailer, left / roadside

STANDARD UNDER 80" TAILLIGHTS

- Designed for a wide variety of utility trailer applications
- Performs six functions: tail, turn and stop lights, side marker and reflector
- Extra "hot" connector wire port included to provide for quick and easy wiring for additional auxiliary lights



JL9854-4 7-function taillight (road side) with license plate light

JL9854-5 6-function taillight (curb side) without license plate light

STANDARD OVER 80" TAILLIGHTS

- Designed for utility trailers 80" wide or wider
- Helps all trailers ensure compliance with DOT-108 when properly mounted
- Incorporated license illuminator (no need for a separate clearance light)

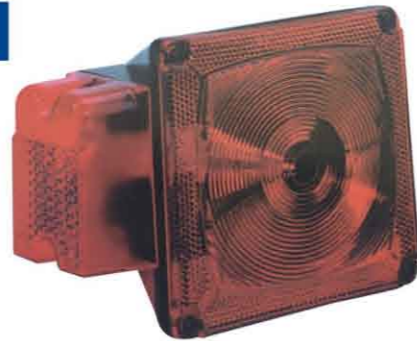

JL9854-6 8-function taillight - road side

JL9854-7 7-function taillight -curb side

SURFACE MOUNT LIGHT

- Multi-function stop/turn/taillight
- Hardware included

JL9854-10 Surface mount stop/turn/taillight



WATERPROOF ROUND TAILLIGHT

- Grommeted taillight performs stop, tail and turn functions
- Designed to be used in industrial and commercial applications
- Sonically sealed polycarbonate lens and base
- Mounts in flush mount grommet to maximize shock proof

JL9854-8 Taillight Set: module, grommet and plug

JL9854-9 Grommet only for round taillights



3-PIECE REPLACEMENT LENS SET

CONTENTS:

- 1 - 4-1/2" square, red with bullseye center
- 1 - 2" x 2-3/4", red
- 1 2" x 2-3/4", amber

JL9854-11 3-piece replacement lens set (under 80" wide trailers)



WATERPROOF LOW-PROFILE TRAILER LIGHT KIT

- Features taillights with replaceable sealed lamp capsules
- Protects bulb and contacts from damage by corrosion
- Contains 2-taillights, 2-side marker lights, 1-license plate bracket, 1-25' wishbone trailer harness, 1-48" connector, hardware, instructions

JL9854-12 Waterproof low-profile taillight kit

JL9854-13 Waterproof low-profile taillight - road side

JL9854-14 Waterproof low-profile taillight - curb side

JL9854-15 Replacement sealed lamp capsule



STANDARD TRAILER LIGHT KIT

- Kit combines standard trailer lights and wiring
- Designed specifically for trailers under 80" wide
- For wider trailers, add clearance lights and ID bars

JL9854-16 Standard taillight kit with 20' harness and marker lights

JL9854-17 Standard taillight kit with 20' harness; no side marker lights



WIRING KIT

www.nb-jiulong.com
www.Jiulongusa.com



WIRING KIT

www.nb-jiulong.com
www.Jiulongusa.com



TRAILER ACCESSORIES

TRAILER ACCESSORIES



JL9855

Plastic 7-way round blade connector (RV blade)/car end



JL9856

7 way plastic trailer end



JL9857

7 to 4 way adapter



JL9858

4-way car and trailer end



JL9859

4-way flat vehicle end connector including 60" of wire

HITCH PIN



JL9860

1/2", chrome



JL9861

5/8", chrome

COUPLER LOCK



JL9862

Coupler pin for fas-lock coupler

SAFETY CHAIN



JL9863

72" long and 2000lbs

JL9864

72" long and 5000lbs

WIRING KIT

www.nb-jiulong.com
www.Jiulongusa.com



TOW ROPE TOW STRAP

www.nb-jiulong.com
www.Jiulongusa.com



SAFETY CABLE



JL9865

Cable is 40" long and protected by vinyl. Capacity 5000lbs

TOW HOOK



JL9865

Tow hook rated at 10,000 lbs (4500 kg)

QUICK LINKS



JL9867 5/16", 5000lbs rating

HITCHBALLWRENCH



JL9869

1-1/8" & 1-1/2" Wrench ends fit the most popular hitch ballnut sizes

TOW BAR



JL9870

5000lbs adjustable tow bar width of 26" to 41" Includes 2" coupler and one set of universal bumper brackets



TOW POPE

JL9871

1/2" x 14' - 2000 lb.
JL9871 w/ storage bag
JL9871-1 - Bulk
1000 lb. MAXIMUM VEHICLE WEIGHT



TOW POPE

JL9872

3/4" x 14' - 6000 lb.
JL9872 w/ storage bag
JL9872-2 - Bulk
3000 lb. MAXIMUM VEHICLE WEIGHT



TOW POPE

JL9873

7/8" x 14' - 8500
JL9873 w/ storage bag
JL9873-1 - Bulk
4250 lb. MAXIMUM VEHICLE WEIGHT



TOW STRAP

JL9874

2" x 15' - 5000 lb.
JL9874 (1-Pack)
JL9874-1 - Bulk
2500 lb. MAXIMUM VEHICLE WEIGHT



TOW STRAP

JL9875

2" x 15' - 8500 lb.
JL9875 (1-Pack)
JL9875-1 - Bulk
4250 lb. MAXIMUM VEHICLE WEIGHT



TOW STRAP

JL9876

1 1/4" x 15' - 4000 lb. RE-TRACTABLE



TOW STRAP

JL9877

2" x 20' - 10,000 lb. RE-TRACTABLE WITH FORGED SAFETY SNAP HOOK
JL9877 (1-PACK)
JL9877-1 - Bulk
5000 lb. MAXIMUM VEHICLE WEIGHT



TOW STRAP

JL9878

1" x 10' - 5000 lb. EMERGENCY SNOWMOBILE

TRAILER ACCESSORIES

TOW ROPES AND STRAPS

LANDING GEAR

www.nb-jiulong.com
www.Jiulongusa.com



LANDING GEAR

www.nb-jiulong.com
www.Jiulongusa.com



JLCL28000A SERIES LANDING GEAR



- Gearbox inside, double speed designed.
- Lead screw is rolled forming with extra-duty feature steel.
- Quality grease can bear hot and cold condition.
- Surface powder coating, delicate, Water-proof and Rust-proof.
- Static load, lift test and drop test accord with ABS.

MODEL	JLCL25000A	JLCL28000A	JLCL30000A
STATIC LOAD CAPACITY(T)	70	80	80
LIFING CAPACITY(T)	25	28	30
HIGH GEAR(mm)	7.5	7.5	7.5
LOW GEAR(mm)	0.84	0.84	0.84
TRAVEL MAX(mm)	17" / 19"	17" / 19"	17" / 19"
HEIGHT(mm)	780 / 830	780 / 830	780 / 830
CRANK FORCE(KG)	25	25	25
WEIGHT(KG)	98	100	102

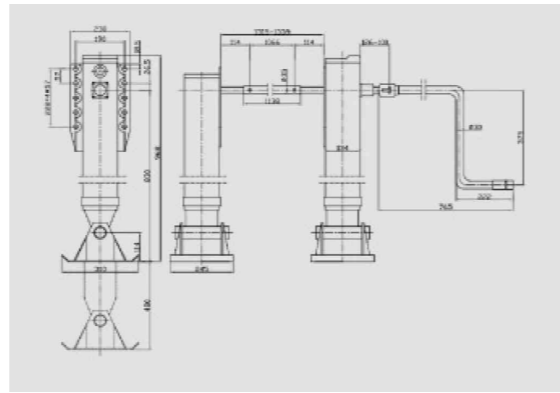

JLCL28000C SERIES LANDING GEAR



- Double speed designed.
- Lead screw is rolled forming with extra-duty feature steel.
- Quality grease can bear hot and cold condition.
- Gears are quality forging instead of weak casting.
- Surface powder coating, delicate, Water-proof and Rust-proof.
- Quality control system guarantee best quality.
- Static load, lift test and drop test accord with ABS specification

MODEL	JLCL25000C	JLCL28000C	JLCL30000C
STATIC LOAD CAPACITY(T)	70	80	80
LIFING CAPACITY(T)	25	28	30
HIGH GEAR(mm)	5.42	5.42	5.42
LOW GEAR(mm)	0.72	0.72	0.72
TRAVEL MAX(mm)	17" / 19"	17" / 19"	17" / 19"
HEIGHT(mm)	780 / 830	780 / 830	780 / 830
CRANK FORCE(KG)	25	25	25
WEIGHT(KG)	98	100	102

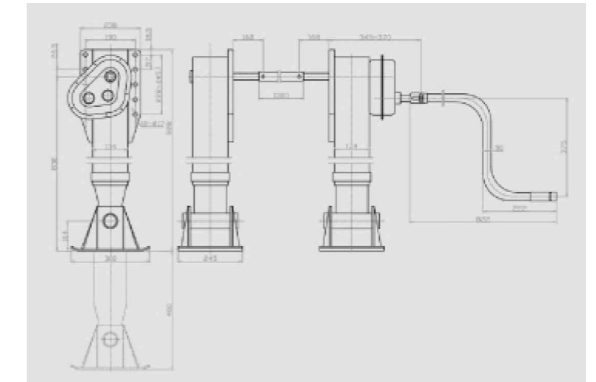

JLCL28000B SERIES LANDING GEAR

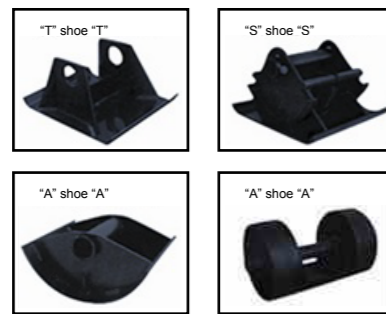

- Gearbox outside, double speed designed.
- Quality grease can bear hot and cold condition.
- Surface powder coating, delicate, rust-proof.
- Multi-type shoes available for different requirement.

MODEL	JLCL25000B	JLCL28000B	JLCL30000B
STATIC LOAD CAPACITY(T)	72	80	80
LIFING CAPACITY(T)	25	28	30
HIGH GEAR(mm)	5.42	5.42	5.42
LOW GEAR(mm)	0.72	0.72	0.72
TRAVEL MAX(mm)	17" / 19"	17" / 19"	17" / 19"
HEIGHT(mm)	792 / 842	792 / 842	792 / 842
CRANK FORCE(KG)	25	25	25
WEIGHT(KG)	100	103	105

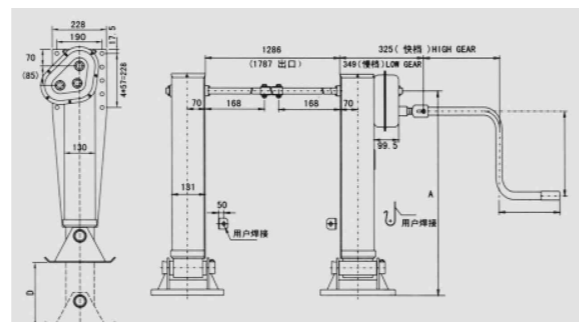

JLCL28000F SERIES LANDING GEAR



- Double speed designed.
- Lead screw is rolled forming with extra-duty feature steel.
- Quality grease can bear hot and cold condition.
- Gears are quality forging instead of weak casting.
- Surface powder coating, delicate, Water-proof and Rust-proof.
- Quality control system guarantee best quality.
- Static load, lift test and drop test accord with ABS Specification.

MODEL	JLCL25000F	JLCL28000F	JLCL30000F
STATIC LOAD CAPACITY(T)	80	80	80
LIFING CAPACITY(T)	25	28	30
HIGH GEAR(mm)	10.8	10.8	10.8
LOW GEAR(mm)	0.8	0.8	0.8
TRAVEL MAX(mm)	17" / 19"	17" / 19"	17" / 19"
HEIGHT(mm)	810 / 860	810 / 860	810 / 860
CRANK FORCE(KG)	35	35	35
WEIGHT(KG)	100	102	105

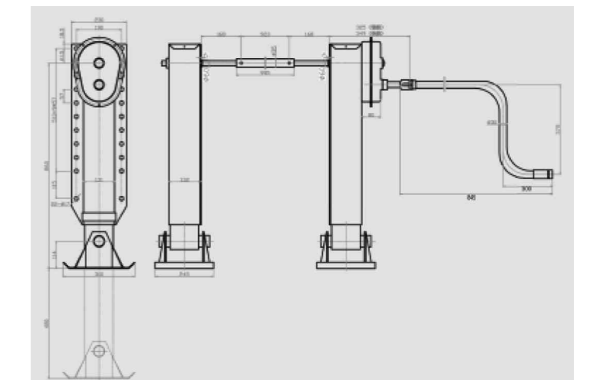

LANDING GEAR

www.nb-jiulong.com
www.Jiulongusa.com



OTHER SERIES LANDING GEAR FOR DIFFERENT MARKETS NEED



JLCL28000D



JLCL28000E



JLCL28000G



JLCL28000H



JLCL10000J



JLCL25000L



JLCL28000M



JLCL16000A

SPARE PARTS SERIES FOR LANDING GEAR



SAND FOOT



SPRING FOOT



ROCKING FOOT



CRANK HANDLE

LANDING GEAR